



SCT603

- thermoelectric sensor with double protection tube
- temperature range $-200...+1600^{\circ}\text{C}$ (depending on thermocouple used)
- operating temperature of connection heads max. 150°C
- thermowell material: 1.4841
- tube made of C610 or C799
- possibility of mounting a 4...20mA or 0...10V temperature transmitter
- mounting by threaded fittings and DN flanges
- connection head DANW with local display

The thermocouple SCT603 is intended for measuring the temperature of pipelines, tanks and boilers. The sensor is designed to work in difficult conditions (gases, vapors) and high temperatures up to 1600°C . The sensor consists of an aluminum connection head, a steel transition cover and a ceramic cover. The sensor is made with a replaceable measuring insert, which makes it possible to regenerate the element without having to dismantle the entire cover.

Application areas

- temperature measurement in thermal processing: furnaces, boilers, furnaces
- industrial installations

TECHNICAL DATA

Sensing element	J, K, N, R, S, B thermocouple or other (single, double)
Measuring range	$-40 \div 1200^{\circ}\text{C}$ (TCK, N), $0 \div 1600^{\circ}\text{C}$ (TCS, R), $600 \div 1700^{\circ}\text{C}$ (TCB)
Connection head	B, NA, MA, DAN or other, operating temperature $-40 \div 150^{\circ}\text{C}$
Class	1 or 2
Sheath	material: C610 (60% Al_2O_3) or C799 (99,7% Al_2O_3) nominal length: any (acc. to order) diameter: single 15 or 20mm; double (outer 20mm / inner 15mm)
Transitional sheath	material: heat-resistant steel 1.4841 diameter: 15 or 22 mm (standard)
Process connection	G1 or flange

DIMENSIONS

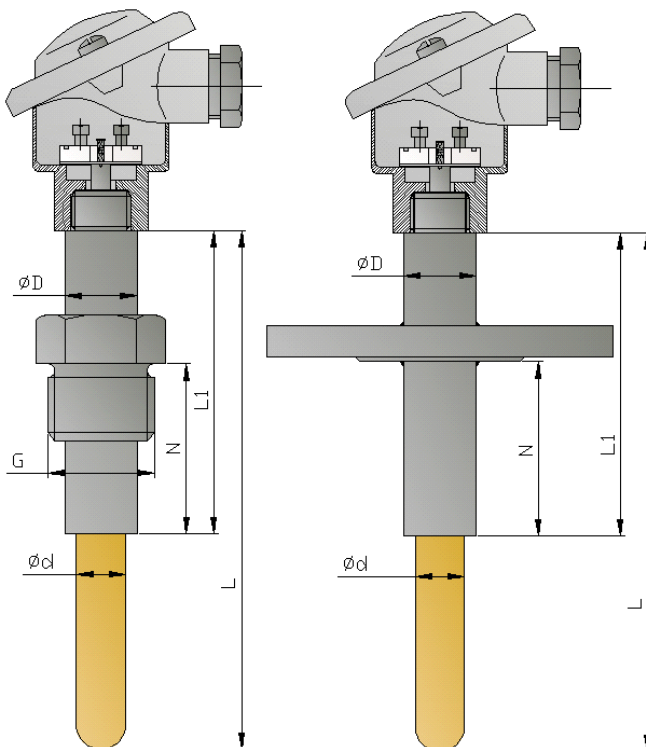

CERAMIC PROTECTION TUBE - FEATURES

Material	Operation temperature	Advantages	Disadvantages	Application
C610 (60% Al ₂ O ₃)	max. 1500°C	gas-tight, average thermal shock resistance, high flame resistance	low resistance to mechanical load, low Al ₂ O ₃ content	gas-tight furnaces, diffusion furnaces
C799 (99,7% Al ₂ O ₃)	max. 1800°C	gas-proof, acid resistant, steam resistant, very high flame resistance	low resistance to mechanical load, low resistance to temperature shock	gas-tight furnaces up to 1800°C (liquid glass tanks), chemical industry, manufacturing of concrete

ORDERING

SCT603-X-X-X-X-X-X-X-X-X-X-X-X-X-X-X-X

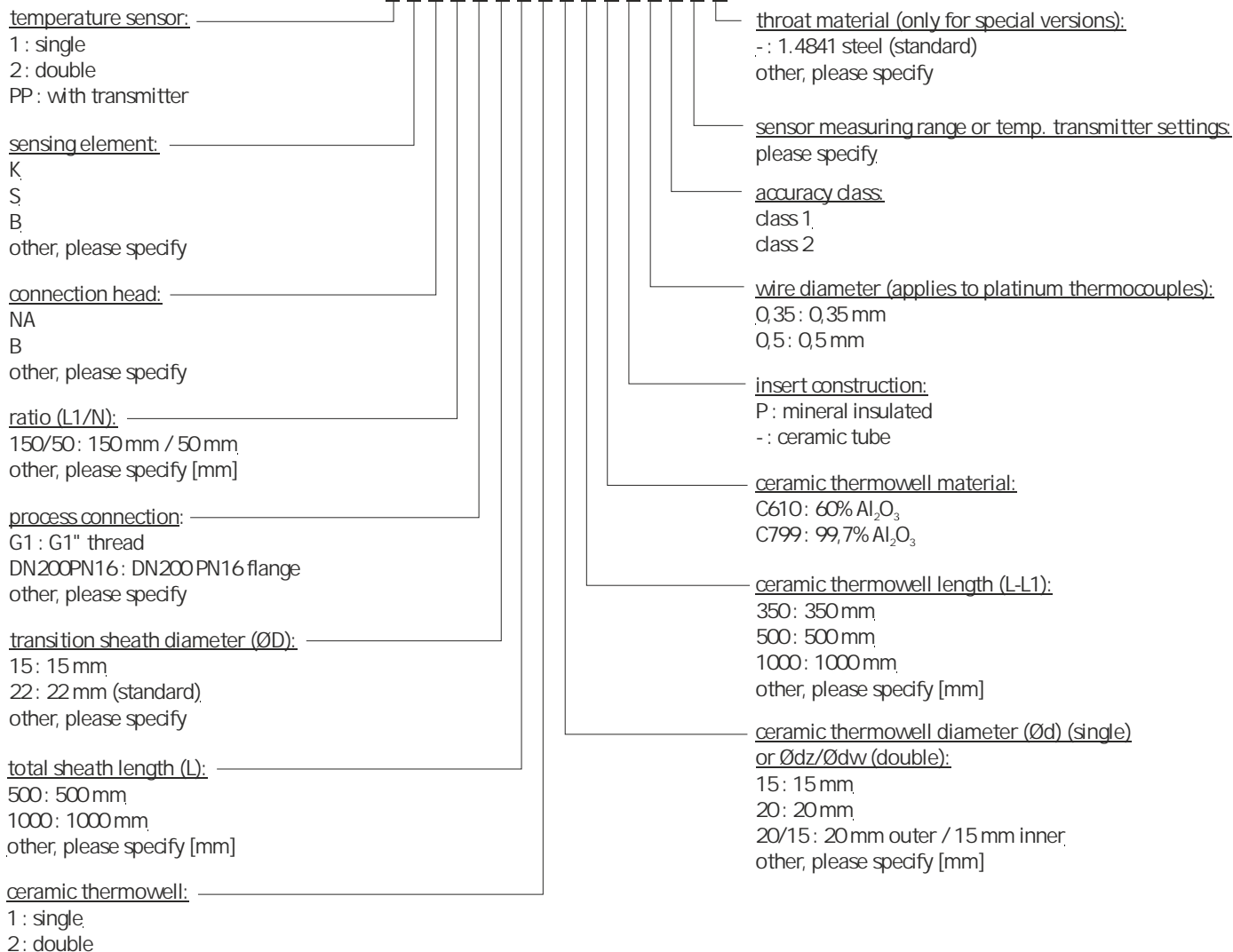

Ordering example:

SCT603-1-K-B-150/50-G1-22-500-2-20/15-350-C799-2-1200

Single TC temperature sensor, K thermocouple, 2 tolerance class, B head type, ceramic protection tube made of C799, 20mm outer, 15 mm inner diameter, 350 mm length, transition sheath diameter 22 mm, total sheath length 500 mm, process connection G1". Sensor measuring range 1200°C.

