

User manual

CONVERTER MODULE

SRS-2/4-Z45

- RS-232 / RS-485 signals conversion



Read the user's manual carefully before starting to use the unit or software.
Producer reserves the right to implement changes without prior notice.

CONTENTS

1. BASIC REQUIREMENTS AND USER SAFETY.....	3
2. GENERAL CHARACTERISTICS.....	4
3. TECHNICAL DATA.....	4
4. DEVICE INSTALLATION.....	5
4.1. UNPACKING.....	5
4.2. CONNECTION METHOD.....	5
4.3. MAINTENANCE.....	8
5. PREPARATION OF THE UNIT TO WORK	8
6. CONNECTION OF THE UNIT WITH TRS SYSTEM	10

Explanation of symbols used in the manual:



- This symbol denotes especially important guidelines concerning the installation and operation of the device. Not complying with the guidelines denoted by this symbol may cause an accident, damage or equipment destruction.

IF THE DEVICE IS NOT USED ACCORDING TO THE MANUAL THE USER IS RESPONSIBLE FOR POSSIBLE DAMAGES.



- This symbol denotes especially important characteristics of the unit. Read any information regarding this symbol carefully

1. BASIC REQUIREMENTS AND USER SAFETY



- **The manufacturer is not responsible for any damages caused by inappropriate installation, not maintaining the proper environmental conditions and using the unit contrary to its assignment.**
- Installation should be conducted by qualified personnel . During installation all available safety requirements should be considered. The fitter is responsible for executing the installation according to this manual, local safety and EMC regulations.
- The unit must be properly set-up, according to the application. Incorrect configuration can cause defective operation, which can lead to unit damage or an accident.
- **If in the case of a unit malfunction there is a risk of a serious threat to the safety of people or property additional, independent systems and solutions to prevent such a threat must be used.**
- Neighbouring and connected equipment must meet the appropriate standards and regulations concerning safety and be equipped with adequate overvoltage and interference filters.
- **Do not attempt to disassemble, repair or modify the unit yourself. The unit has no user serviceable parts. Defective units must be disconnected and submitted for repairs at an authorized service centre.**



- In order to minimize fire or electric shock hazard, the unit must be protected against atmospheric precipitation and excessive humidity.
- Do not use the unit in areas threatened with excessive shocks, vibrations, dust, humidity, corrosive gasses and oils.
- Do not use the unit in areas where there is risk of explosions.
- Do not use the unit in areas with significant temperature variations, exposure to condensation or ice.
- Do not use the unit in areas exposed to direct sunlight.
- Make sure that the ambient temperature (e.g. inside the control box) does not exceed the recommended values. In such cases forced cooling of the unit must be considered (e.g. by using a ventilator).



The unit is designed for operation in an industrial environment and must not be used in a household environment or similar.

2. GENERAL CHARACTERISTICS

The **SRS-2/4-Z45** converter module is designed to interconnect MASTER devices equipped with RS-232 to RS-485 bus. The module can work either with devices controlling direction of transmission (via RTS line), or devices not controlling the direction (control is then fully automatic). The MASTER functions can be realized by any device, e.g. PC computer with dedicated software. Connection of more than one MASTER device to the RS-485 bus is prohibited.

The **SRS-2/4-Z45** unit guarantees full galvanic isolation between RS-232 and RS-485 circuits. Warning - only one **SRS-2/4-Z45** can be connected to RS-485 line.

The converter can work with any devices equipped with RS-485 interface, especially made by SIMEX.

The main purpose of **SRS-2/4-Z45** converter is connection of PC host computer with industrial data acquisition and visualisation systems based on RS-485 interface.



The device is equipped with RS-232 cable which should not be prolonged (due to limitations of the RS-232 interface standard)

3. TECHNICAL DATA

Power supply voltage	9 ÷ 30 V DC
Power consumption	max. 1,6 W
Galvanic separation	between RS 485 line and RS 232 interface.
RS 232 connector	1x 9 PIN Canon (RS232), cable (length about 1,3 m) is delivered with the unit
Transmission parameters	2400 ÷ 115200/8/1/N (without direction control by RTS) 1200 ÷ 115200/8/1/N (with direction control by RTS)
Delay to transmitter switch off	typical 1.5 character (do not apply controlling by RTS)
Housing dimensions	40 x 55 x 100 mm
Weight	170 g
Operating temperature (depending on version)	0°C to +50°C or -20°C to +50°C
Storage temperature (depending on version)	-10°C to +70°C or -20°C to +70°C
Humidity	5 to 90% no condensation
Altitude	up to 2000 meters above sea level
Screws tightening max. torque	0,5 Nm
Max. connection leads diameter	2,5 mm ²
EMC	PN-EN 61326:2003



This is a class A unit. In housing or a similar area it can cause radio frequency interference. In such cases the user can be requested to use appropriate preventive measures.

4. DEVICE INSTALLATION

The unit has been designed and manufactured in a way assuring a high level of user safety and resistance to interference occurring in a typical industrial environment. In order to take full advantage of these characteristics installation of the unit must be conducted correctly and according to the local regulations.



- Read the basic safety requirements on page 3 prior to starting the installation.
- All installation works must be conducted with a disconnected power supply.
- Protecting the power supply clamps against unauthorized persons must be taken into consideration.

4.1. UNPACKING

After removing the unit from the protective packaging, check for transportation damage. Any transportation damage must be immediately reported to the carrier. Also, write down the unit serial number on the housing and report the damage to the manufacturer.

Attached with the unit please find:

- user's manual for **SRS-2/4-Z45** device.

4.2. CONNECTION METHOD

Caution



- Installation should be conducted by qualified personnel . During installation all available safety requirements should be considered. The fitter is responsible for executing the installation according to this manual, local safety and EMC regulations.
- Wiring must meet appropriate standards and local regulations and laws.
- In order to secure against accidental short circuit the connection cables must be terminated with appropriate insulated cable tips.
- Tighten the clamping screws. The recommended tightening torque is 0.5 Nm. Loose screws can cause fire or defective operation. Over tightening can lead to damaging the connections inside the units and breaking the thread.
- In the case of the unit being fitted with separable clamps they should be inserted into appropriate connectors in the unit, even if they are not used for any connections.

Due to possible significant interference in industrial installations appropriate measures assuring correct operation of the unit must be applied. To avoid the unit of improper work keep recommendations listed below.

- Avoid common (parallel) leading of signal cables and transmission cables together with power supply cables and cables controlling induction loads (e.g. contactors). Such cables should cross at a right angle.
- Contactor coils and induction loads should be equipped with anti-interference protection systems, e.g. RC-type.
- Use of screened signal cables is recommended. Signal cable screens should be connected to the earthing only at one of the ends of the screened cable.
- In the case of magnetically induced interference the use of twisted couples of signal cables (so-called "spirals") is recommended. The spiral (best if shielded) must be used with RS-485 serial transmission connections.
- In the case of interference from the power supply side the use of appropriate anti-interference filters is recommended. Bear in mind that the connection between the filter and the unit should be as short as possible and the metal housing of the filter must be connected to the earthing with largest possible surface. The cables connected to the filter output must not run in parallel with cables with interference (e.g. circuits controlling relays or contactors).

The connections should be made accordingly to sticker on the top of converter's housing (Figure 4.1 - 4.2).

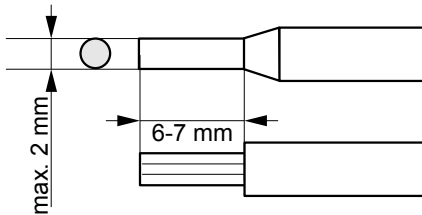

Figure 4.1. Method of cable insulation replacing and cable terminals

Push-button and LEDs functions:

- LED **pwr** (green) - power on (lights constantly),
- programming mode (flashes),
- LED **pd2** (yellow) - turning on the RS-485 transmitter (while normal operation),
- current configuration (while programming mode),
- LED **pd1** (red) - data transmission to RS-485 interface (while normal operation),
- current configuration (while programming mode),
- LED **pd0** (green) - data receiving from RS-485 interface (while normal operation),
- current configuration (while programming mode),
- prg** button - programming button

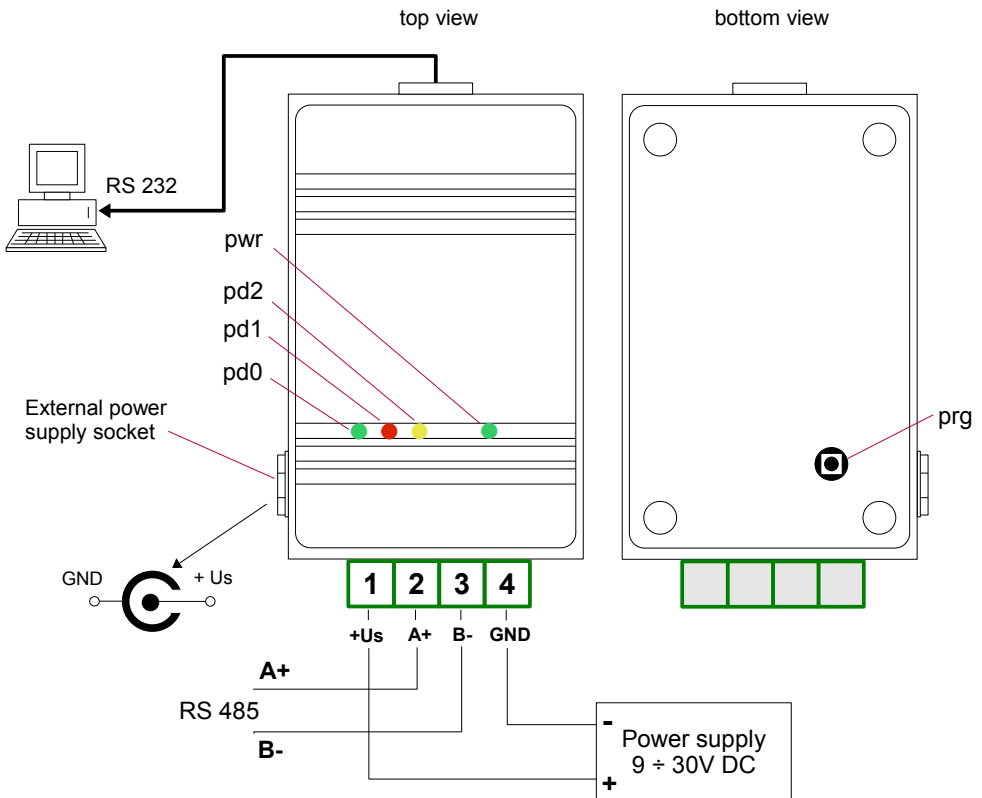

Figure 4.2 Connection method

4.3. MAINTENANCE

The unit does not have any internal replaceable or adjustable components available to the user. Pay attention to the ambient temperature in the room where the unit is operating. Excessively high temperatures cause faster ageing of the internal components and shorten the fault-free time of unit operation.

In cases where the unit gets dirty do not clean with solvents. For cleaning use warm water with small amount of detergent or in the case of more significant contamination ethyl or isopropyl alcohol.



Using any other agents can cause permanent damage to the housing.



Product marked with this symbol should not be placed in municipal waste. Please check local regulations for disposal and electronic products.

5. PREPARATION OF THE UNIT TO WORK

The baud rate of the **SRS-2/4-Z45** converter is defined while programming mode. It is possible to set baud rate from 2400 baud to 115200 baud (Tab. 5.1) or enable control of the transmission's direction by MASTER via RTS line. **Controlling of the direction by MASTER allows transmitting data with baud rate 1200 to 115200 baud.**

The programming of the device is realized using **prg** button, available from the bottom of the device. Due to the button is mounted inside the device, use slim tool to press it (e.g. small screwdriver or match).



While programming, it is recommended to disconnect the device from RS-232 socket, to avoid of erratic identification of the programmed mode.

To program the device, following steps should be done:

1. connect power supply (24V DC) to the converter terminals marked **+Us** and **GND**. The green led **pwr** will light constantly ;
2. press and hold at least 4 seconds the **prg** button. Led **pwr** will start flashing, signalling that programming mode is enabled. The rest of LEDs (**pd2**, **pd1**, **pd0**) will indicate current configuration (Tab. 5.1);
3. press (short) programming button – configuration will change, LEDs **pd2**, **pd1**, **pd0** will indicate new states. Press the button as much as required to set desired configuration (Tab. 5.1);
4. press and hold at least 4 seconds the **prg** button. Led **pwr** will stop flashing, and signalise storing of the configuration and normal operation mode.

LEDs state (1 - lights, 0 - dimmed)			baud rate [baud]
pd2	pd1	pd0	
0	0	0	Selected by MASTER using RTS line
0	0	1	2400
0	1	0	4800
0	1	1	9600
1	0	0	19200
1	0	1	38400
1	1	0	57600
1	1	1	115200

Tab. 5.1 Signalisation of the device's configuration, by LEDs **pd2**, **pd1**, **pd0**

Example: Selection of baud rate - 9600 baud.

- press and hold at least 4 seconds the **prg** button. Led **pwr** will start flashing, signalling that programming mode is enabled.
- press (short) programming button few times, until LEDs **pd2**, **pd1**, **pd0** will indicate the state **0, 1, 1**, (where: 1 – led lights, 0 -led dimmed);
- press and hold at least 4 seconds the **prg** button. Led **pwr** will stop flashing, and signalise storing of the configuration and normal operation mode.

6. CONNECTION OF THE UNIT WITH TRS SYSTEM

The **SRS-2/4-Z45** module is not equipped with internal terminator. If the unit is installed on one end of RS-485 line external terminator must be installed (Figure 6.1). The RS 485 line should be equipped with terminators on both it's ends(Figure 6.2), RS-485 line can't be branched and longer than 1 km.

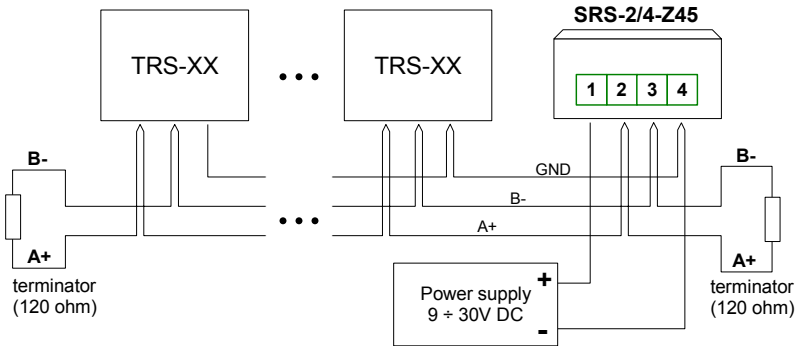

Figure 6.1 Proffered connection method

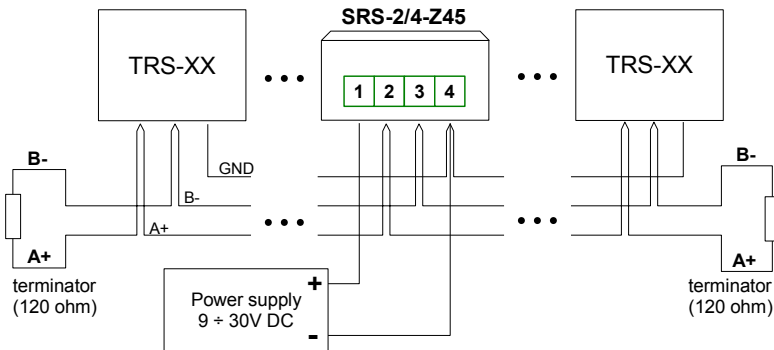
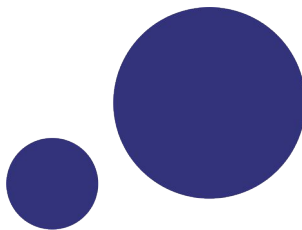

Figure 6.2 Accepted connection method



**SIMEX Sp. z o.o.
ul. Wielopole 7
80-556 Gdańsk
Poland**

**tel.: (+48 58) 762-07-77
fax: (+48 58) 762-07-70**

**<http://www.simex.pl>
e-mail: info@simex.pl**